

TF 4213 RT 964836 Planter

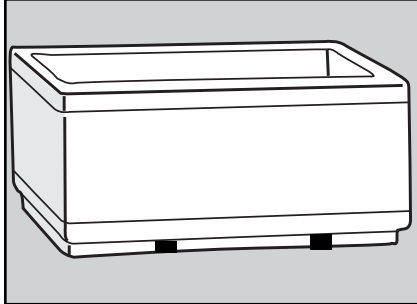

Options:

Note: Options may change without notice.
Call to confirm current options.

Exposed Aggregate:

Tan w/Gray Matrix - Tan w/Brown Matrix
Tan w/Sand Matrix - Misty Gray w/Gray

Weatherstone:

Sand - Gray - Brown - Buff - Cream
Light Charcoal - French Gray - Brick Red

Granitex (GTX)

2078F, 4028F, 6208F, 1168F, 2098F

Custom Options Available

Size: 96" x 48" x 36".
 Weight: 4300 lbs.
 Material: Reinforced Precast Concrete.
 Wall Thickness: 3" at the top with a 3% pitch.
 Features: Forklift slots cast in for moving planter.
 Top edge and reveal line is smooth concrete when planter is exposed aggregate. A smooth top edge and reveal line must be specified when ordering weatherstone finishes. GTX finish is fully exposed.
 Reinforcing: 3/8" Dia. steel rebar.
 Hardware: (4) - 1/2" Dia. threaded inserts.
 (4) - 5/8" Dia. lifting inserts.
 Reservoir System: Optional. Available upon request.
 Drain Hole: (3) - 2" Dia.
 Anchoring: Optional.
 Maintenance: Rinse periodically with water & mild detergent.
 Re-seal annually.
 Packaging: Banded to pallet.

*NOTE:

Lifting inserts are to ONLY be used when the planter is EMPTY.

GENERAL PLANTER SPECIFICATIONS

TF 4213 RT 964836 Planter

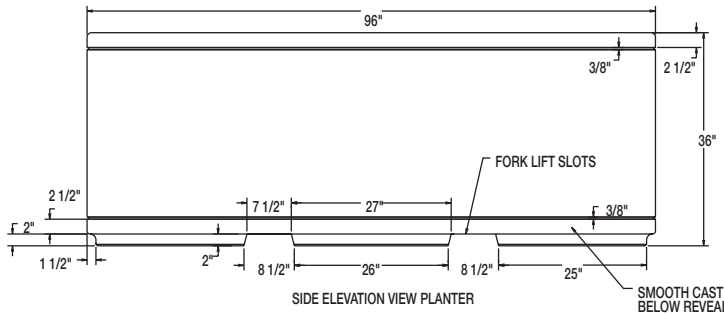
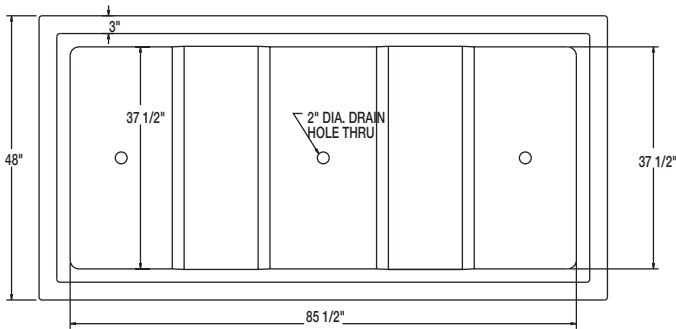

1.1 SUMMARY

- A. Section includes: Furnish Precast Concrete Planter indicated on drawings or specified herein.

1.2 REFERENCES

- A. American Society for Testing & Materials
 - 1. ASTM C33
 - 2. ASTM C150
 - 3. ASTM C31

1.5 SUBMITTALS

- A. Submit product data, shop drawings and Samples.
 - 1. Product Data: Manufacturer's specifications and technical data edited specifically for proposed system, including the following specific information:
 - a. Detailed specification of construction fabrication.
 - b. Manufacturer's installation instructions
 - c. Maintenance literature
 - d. Product warranty
 - 2. Shop Drawings: Indicate pertinent dimensions, general construction, component connections anchoring methods, hardware and installation procedures.
 - 3. Samples as requested by Architect.

1.6 QUALITY ASSURANCE

- A. Qualifications of Manufacturer: Manufacturer to be prequalified by specifier prior to bidding. Failure to comply will result in disqualification of bid. Manufacturer to have at least five years experience in the manufacturer of precast concrete planters field proven for at least five years.

1.10 WARRANTY

Manufacturer shall submit a written warranty for precast products for the period of two years upon acceptance of products.

2.1 MANUFACTURERS

- A. Acceptable manufacturer for Precast Concrete Planters to be known as

Wausau Tile, Inc. Terra-Form Division.
PO Box 1520, Wausau, WI 54402-1520.
(800) 388-8728 FAX (715) 355-4627

- B. Clarification Note: Drawings and installation specification are based on manufacturers proprietary literature from Wausau Tile, Inc. Other manufacturers shall comply with minimum levels of material and detailing indicated on drawings or specified herein.
- C. All Precast products for this project shall be of one manufacturer.

2.2 MATERIALS

- A. Portland Cement: ASTM C150 specifications for Portland Cement.
- B. Aggregates: All aggregates to meet ASTM C33 specifications, to be cleaned of foreign matter and properly graded to size.
- C. Coloring: Pigments used shall be inorganic, resistant to alkalinity and used as per manufacturers recommendations.