

PSB2200N

GE Profile Advantium® 240 Wall Oven

Advantium wall oven/GE Profile cooking tower dimensions and cabinet installation information (in inches)

Note: Cabinets installed adjacent to wall ovens must have an adhesion spec of at least a 194°F temperature rating.

Note: 2" minimum between cutouts when installed above warming drawer or single wall oven.

Installation Information:

Before installing, consult installation instructions packed with product for current dimensional data.

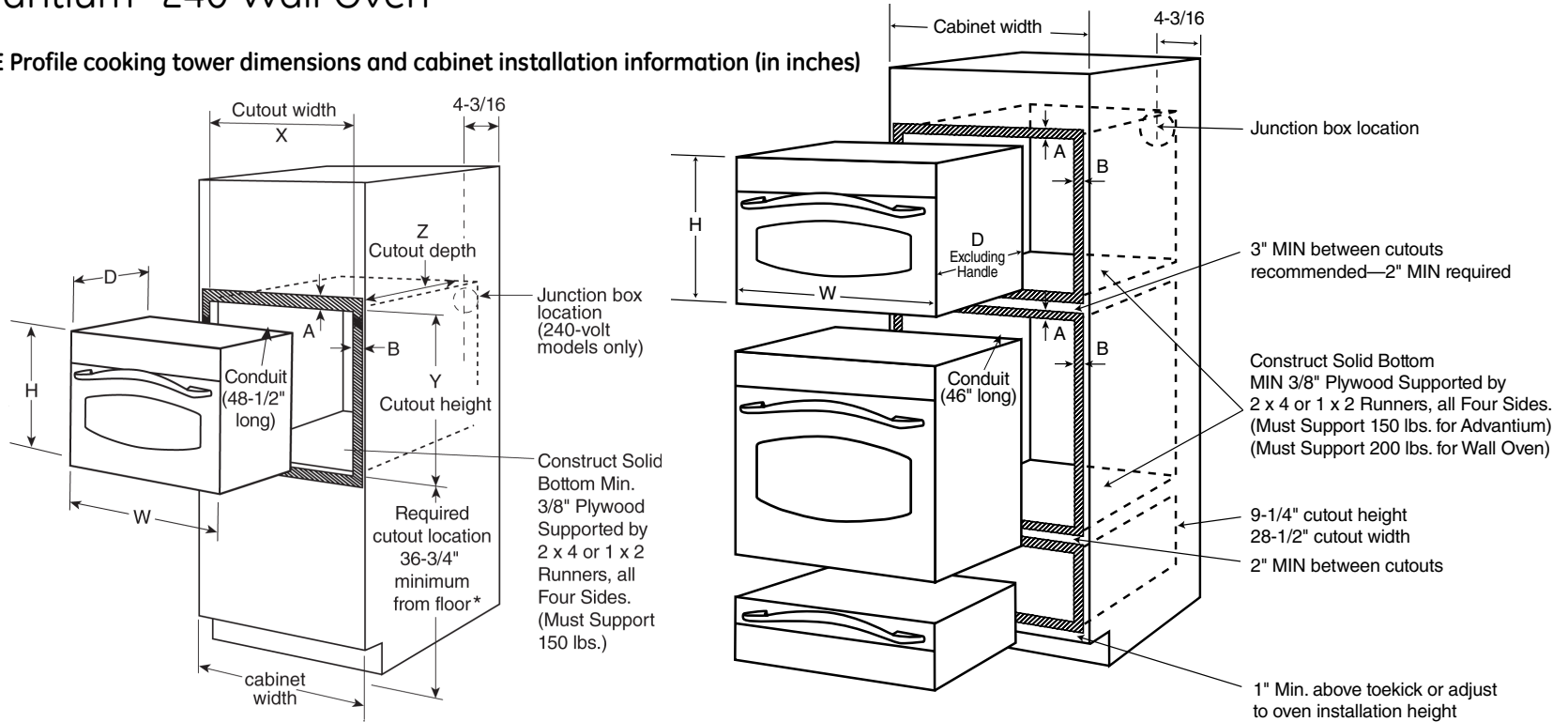

A=Allow 7/8" overlap of oven over bottom and 1/4" overlap at top edges of cutout.
 B=Allow 2-1/8" for overlap of oven over side edges of cutout.

A=Allow 7/8" overlap of oven over bottom and 1/4" overlap at top edges of cutout.
 B=Allow 2-1/8" for overlap of oven over side edges of cutout.

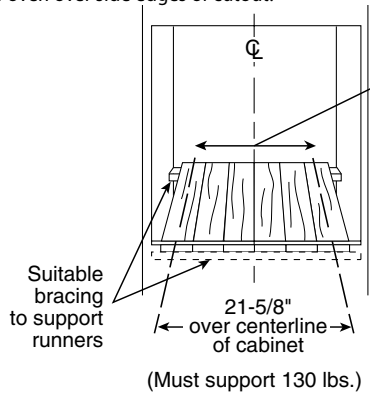

| | Cabinet Width (inches) | W Width | H Height | D Depth (excluding handle) | X Cutout Width | Y Cutout Height | Z Cutout Depth (minimum) |
|------------------------------------|------------------------|----------|----------|----------------------------|-------------------|-----------------|--------------------------|
| PSB2200/1 without accessory drawer | 30 | 29-25/32 | 19-1/8 | 21-1/2 | 25-1/8 | 17-1/2 | 23-1/2 |
| PSB2200/1 with accessory drawer | 30 | 29-25/32 | 22-1/4 | 21-3/4 | 25-1/8 to 28-1/2* | 21 | 23-1/2 |

*For existing cutouts a maximum width of 28-1/2" is acceptable

For answers to your Monogram®, GE Profile™ or GE® appliance questions, visit our website at ge.com or call GE Answer Center® service, 800.626.2000.



PSB2200N

GE Profile Advantium® 240 Wall Oven

Preparation WITH an Accessory Drawer

Prepare the opening

The Advantium 240V can be installed in combination with other GE/Monogram appliances. Always follow each product's Installation Instructions to complete the installation.

Single Advantium 240V Installation:

Order a 30" wide single oven cabinet or cut the opening in a wall to the dimensions shown.

* For existing cutouts, a maximum width of 28-1/2" is acceptable. If the opening is slightly wider, secure a furring strip on each side of the cutout for securing the oven.

- Always maintain 36-3/4" minimum height from the floor to the cutout in any single or combined installation.
- Allow 3/4" to 2-1/8" case trim overlap on the sides and 7/8" overlap on the bottom of the opening for all models. The amount of overlap on the sides depends on the actual cutout width. Allow 1-1/4" case trim overlap on the top for models PSB2200 and PSB2201 and for models ZSC2200, ZSC2201 and ZSC2202.
- Oven overlaps will conceal cut edges on all sides of the opening.

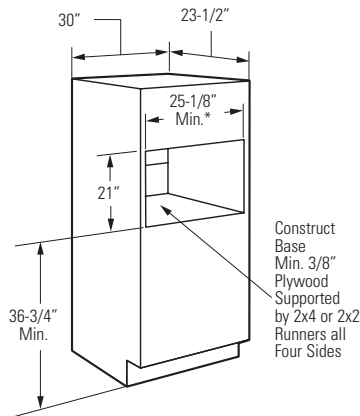

For answers to your Monogram®, GE Profile™ or GE® appliance questions, visit our website at ge.com or call GE Answer Center® service, 800.626.2000.



Prepare the opening (cont.)

When installed over a single oven or a warming drawer, allow at least 2" between the two openings. This separation will provide clearance for bottom overlap of the Advantium 240V and the other appliance overlaps.

Construct a solid oven floor of 3/8" min. thick plywood supported by 2 x 4 or 2 x 2 runners on all sides.

- the support must be level and rigidly mounted, flush with the bottom edge of the cutout.

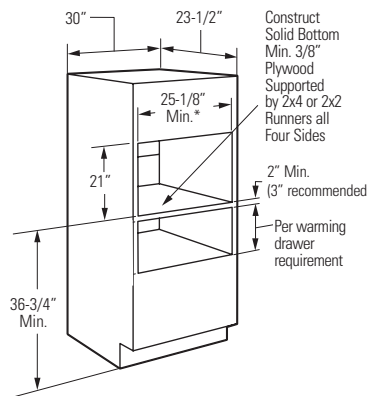

* For existing cutouts, a maximum width of 28-1/2" is acceptable. If the opening is slightly wider, secure a furring strip on each side of the cutout for securing the oven.

Note: Additional clearances between the cutouts may be required. Check to be sure the oven supports above the Warming Drawer location do not obstruct the required interior depth and height. See Warming Drawer installation instructions for details.

Installation over a GE/Monogram Oven and Warming Drawer:

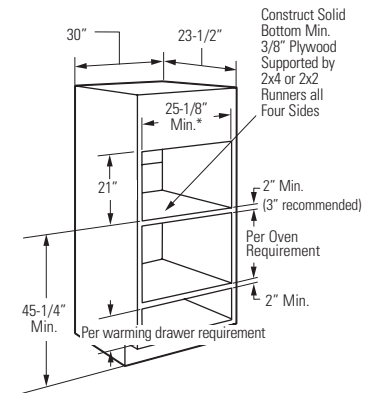

* For existing cutouts, a maximum width of 28-1/2" is acceptable. If the opening is slightly wider, secure a furring strip on each side of the cutout for securing the oven.

Note: Additional clearances between the cutouts may be required. Check to be sure the oven supports above the Warming Drawer location do not obstruct the required interior depth and height. See Warming Drawer installation instructions for details.

CAUTION: For personal safety, the mounting surface must be capable of supporting the cabinet load, in addition to the added weight of this approximate 80-pound oven and 30-pound drawer, plus additional oven loads of up to 50 pounds or a total weight of 160 pounds.



PSB2200N

GE Profile Advantium® 240 Wall Oven

Features and Benefits

- Speedcook Technology - Cooks up to 8 times faster than a conventional oven
- 4 Ovens in 1 to Meet Your Cooking Needs - Speedcook, True European Convection, Warming/Proofing, Sensor Microwave
- Optimizes cook time for consistent results
- Saves valuable time by eliminating preheating
- 16" Turntable - Allows complete rotation of a 9" x 13" casserole dish
- Over 175 preprogrammed recipes
- Full-width oven rack for multi-level cooking
- Includes speedcooking grill tray for preparing meats
- Model PSB2200NWW - White on white
- Model PSB2200NBB - Black on black

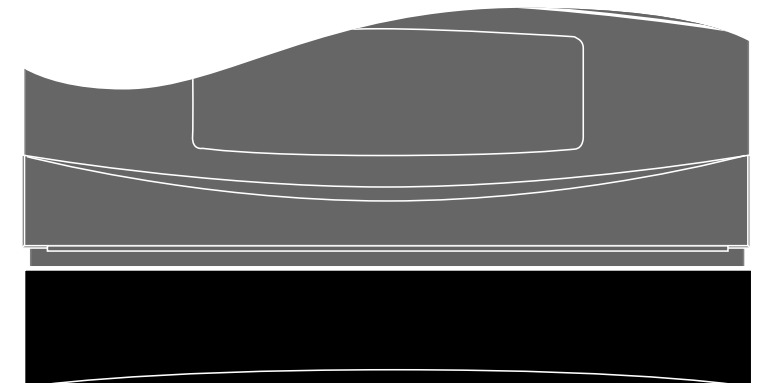
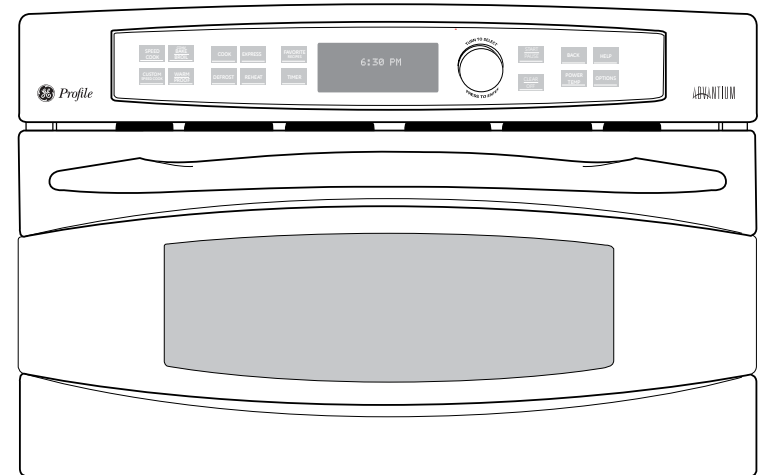

Accessories:

Optional
Storage
Drawer
Available
(JX2200NBB)

For answers to your Monogram,® GE Profile™ or GE® appliance questions, visit our website at ge.com or call GE Answer Center® service, 800.626.2000.



imagination at work